

Your Visions
will expand



■ compact industrial CCD & CMOS camera series with Gigabit Ethernet

■ high quality sensors up to 1600 x 1200 pixels

■ monochrome and color versions

■ integrated image preprocessing

■ Hardware Real-Time Controller (HRTC)

mvBlueCOUGAR

more and up-to-date infos see ▼

www.matrix-vision.com/mvBlueCOUGAR

The MATRIX VISION mvBlueCOUGAR is a compact industrial camera.

The Gigabit Ethernet interface transfers high data rates over long distances using inexpensive standard network parts. Several CCD and CMOS sensors are available, all

delivering superior image quality. Some unique features allow an easy integration in the environment and support the application to deliver faster and better results.

Hardware

<ul style="list-style-type: none"> ▶ Gigabit Ethernet interface ▶ distances up to 100 meters without switch ▶ Power over Ethernet (10/100 MBit/s) ▶ asynchronous trigger via digital input or GigE ▶ opto-isolated digital I/O: <table border="0" style="margin-left: 20px;"> <tr> <td>2 inputs (trigger)</td> <td>logic/PLC level</td> </tr> <tr> <td>2 outputs (strobe)</td> <td>30 V/100 mA</td> </tr> </table> ▶ Hardware Real-Time Controller (HRTC) for time critical I/O and acquisition control ▶ CCD sensors with full frame shutter ▶ ADC resolution: 8/10 bits ▶ input LUT ▶ progressive scan ▶ flexible binning modes for increased frame rate and sensitivity 	2 inputs (trigger)	logic/PLC level	2 outputs (strobe)	30 V/100 mA	<ul style="list-style-type: none"> ▶ partial scan for faster chart acquisition ▶ overlapped exposition and image transfer ▶ automatic gain control (AGC) ▶ automatic exposure control (AEC) ▶ C-mount, CS-mount or optional S-mount ▶ back-focus-adjustment ▶ connectors: <table border="0" style="margin-left: 20px;"> <tr> <td>RJ-45</td> <td>Gigabit Ethernet</td> </tr> <tr> <td>Sub-D 9-pin male</td> <td>digital I/O</td> </tr> <tr> <td>circular plug-in connector</td> <td>power supply</td> </tr> </table> ▶ weight without lens: approx. 200 g ▶ power consumption < 5 W ▶ size without C-mount lens (l x w x h): 96 x 38.8 x 38.8 mm 	RJ-45	Gigabit Ethernet	Sub-D 9-pin male	digital I/O	circular plug-in connector	power supply
2 inputs (trigger)	logic/PLC level										
2 outputs (strobe)	30 V/100 mA										
RJ-45	Gigabit Ethernet										
Sub-D 9-pin male	digital I/O										
circular plug-in connector	power supply										

Software

- ▶ Windows® and Linux® drivers (mvIMPACT Acquire)
- ▶ GigE Vision
- ▶ comes with free mvIMPACT Base

Legal notice: The contents of this brochure are intended to provide information only and to show possible examples. We reserve the right to change technical data and construction at any time without prior notice. The technical specifications of customer systems and of our current products have to be clarified when ordering. Date 04/2006



MATRIX VISION GmbH
Talstrasse 16
DE-71570 Oppenweiler
Phone: +49-7191-9432-0
Fax: +49-7191-9432-88
info@matrix-vision.de

RECOGNIZE ANALYZE DECIDE

Available sensors								
Model name	mvBlueCOUGAR -120		mvBlueCOUGAR -121		mvBlueCOUGAR -124		mvBlueCOUGAR -102	
Model variant	G Gray	C Color	G Gray	C Color	G Gray	C Color	G Gray	C Color
▶ Sensor supplier	Sony		Sony		Sony		Kodak	
▶ Sensor name	ICX098AL/BL		ICX204AL/AQ		ICX274AL/AQ		KAC-9638/48	
▶ Sensor type	CCD		CCD		CCD		CMOS	
▶ Sensor diagonal in [mm]	4.5		6		8.923		8	
▶ Indication of lens category to be used	1/4"		1/3"		1/1.8"		1/2"	
▶ Resolution of sensor's active area (width x height in [pixels])	640 x 480		1024 x 768		1600 x 1200		1280 x 1024	
▶ Pixel size (width x height in [μm])	5.6 x 5.6		4.65 x 4.65		4.4 x 4.4		6 x 6	
▶ Readout type	Progressive		Progressive		Progressive		Progressive	
▶ Transfer/shutter type	Full Frame		Full Frame		Full Frame		Rolling	
▶ Maximum frame rate [Hz]	60		39		16		16	
▶ Exposure (step width)	50 μs – 10 s (1 μs)		50 μs – 10 s (1 μs)		50 μs – 10 s (1 μs)		100 μs – 1 s (50 μs)	

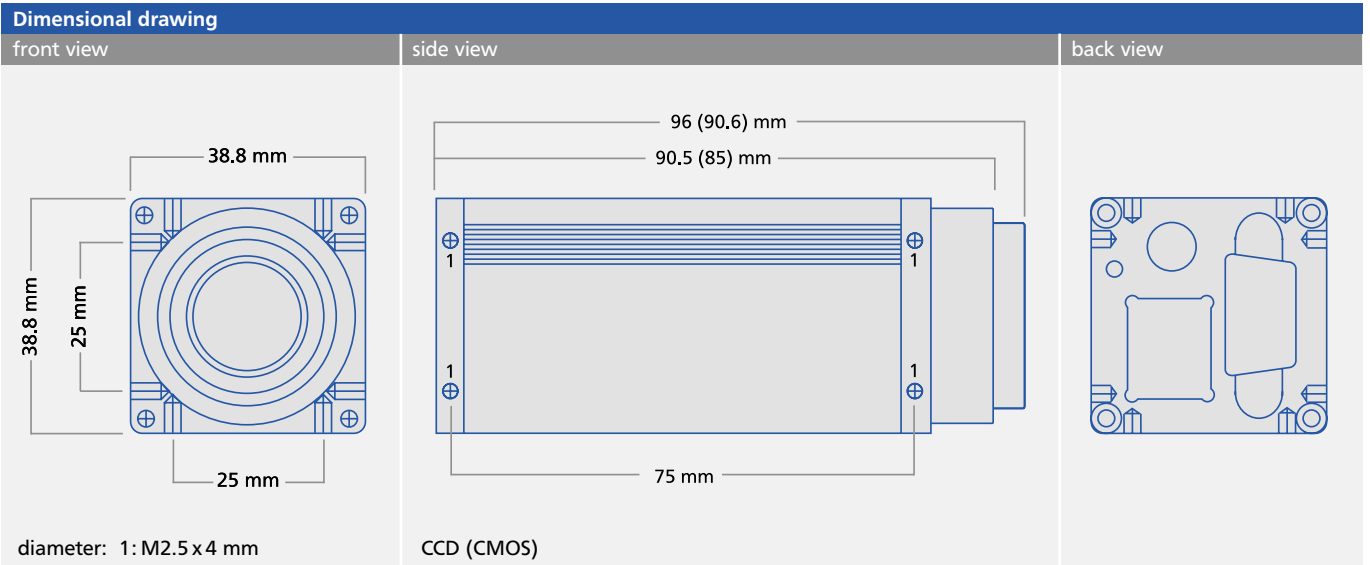

Application areas

- ▶ machine vision
- ▶ robotics
- ▶ surveillance
- ▶ medical imaging

Legal notice: The contents of this brochure are intended to provide information only and to show possible examples. We reserve the right to change technical data and construction at any time without prior notice. The technical specifications of customer systems and of our current products have to be clarified when ordering. Date 10/2005



MATRIX VISION GmbH

Talstrasse 16
DE-71570 Oppenweiler
Phone: +49-7191-94 32-0
Fax: +49-7191-94 32-88
info@matrix-vision.de

RECOGNIZE ANALYZE DECIDE